

## SPARE PARTS ORDERING FORM MINIATURE ELECTROMAGNETIC BRAKES & CLUTCHES

- Step 1.** Identify your part from pictures below.
- Step 2.** Measure indicated dimensions and enter them into the document.
- Step 3.** Fill out your contact information
- Step 4.** E-mail the PDF document to Brakeclutch, LLC. The quote for requested spare parts will be e-mailed to you in return.

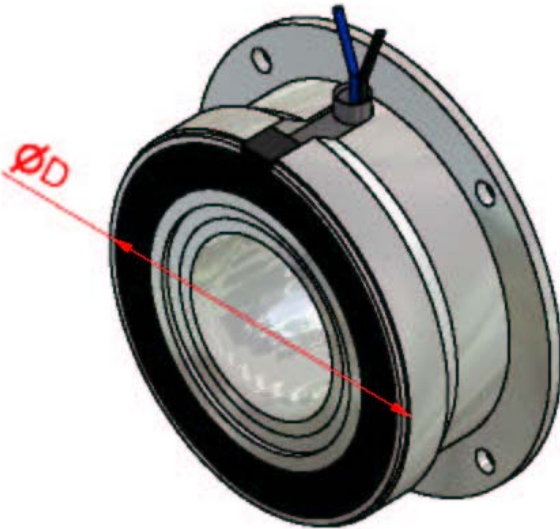

**Stator for brakes**

Stator for brakes **design type 100**

D =

Quantity required:

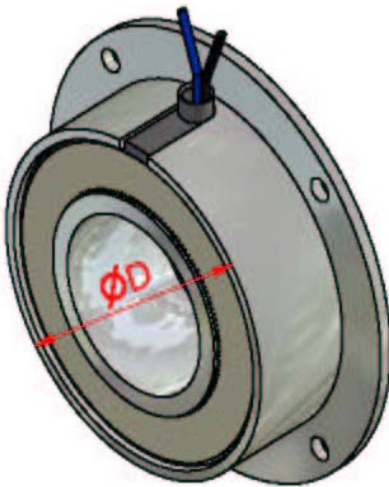

**Stator for clutches**

Stator for clutches **design type 100**

D =

Quantity required:

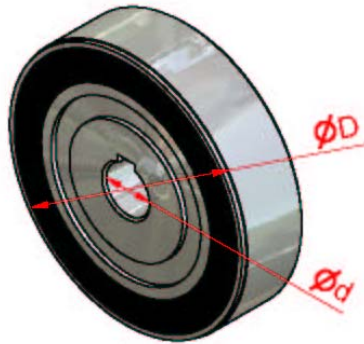

**Rotor for clutches**

Rotor for clutches **design type 010**

D =

d =

Quantity required:

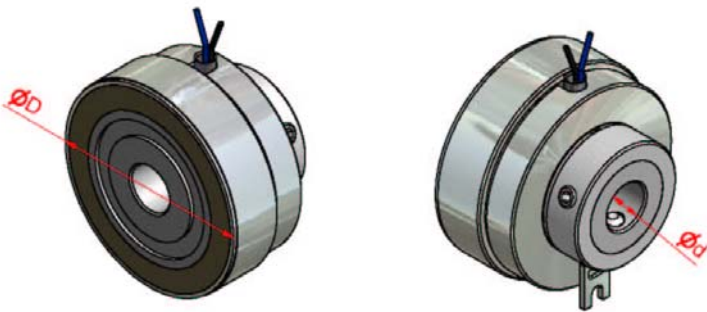

**Stator with rotor complete for clutches**

Stator with rotor complete  
**design type 300**

D =

d =

Quantity required:

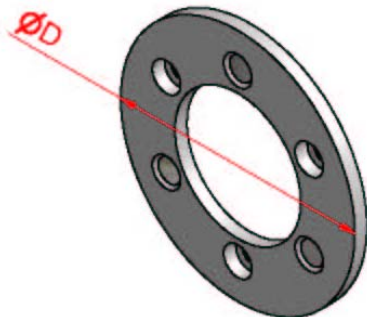

**Armature**

Armature **design type 003**

D =

Quantity required:

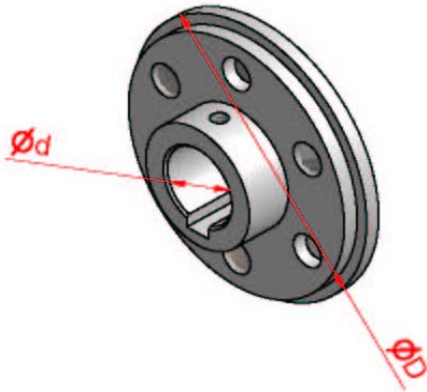

**Armature**

Armature **design type 001**

D =

d =

Quantity required:

---

Company name:

Your name:

Telephone:

Fax:

E-mail:

---

[Click here to e-mail this form](#)

It is possible that your system is not compatible with the software used to create this document and e-mail does not work. In this case please print this document, made manual entries and fax it to: 973-584-2371.